

Insulation

- [Introduction to Insulation](#)
- [R-value](#)
- [Insulation Materials](#)
- [Safety Equipment](#)
- [Seal Leaks Before You Insulate](#)
- Places to Insulate
 - [Basements and Crawl Spaces](#)
 - [Attics](#)
 - [Walls](#)
 - [Windows](#)
- [Inspecting the Work](#)
- [Insulation Checklist](#)
- [For More Information](#)

Introduction to Insulation

Insulating your home provides many benefits for you and your family. Most importantly, insulation lowers your fuel bills and makes your home easier to keep warm in the winter and cool in the summer. Especially in older homes, if you spend your time and money wisely, the improvements you make will pay for themselves in energy dollar savings alone.

R-Value ([top](#))

R-value describes a material's resistance to the flow of heat. The higher the R-value, the slower heat will travel or conduct through a material. Good insulating materials tend to have high R-values. Some R-values of common building and insulation materials are listed below:

BUILDING MATERIALS: R-value
single pane of glass 1.0
basement concrete block 1.0 - 1.5
1/2" drywall or plywood 0.5
air space (at least 3/4") 1.0
uninsulated attic 3.5
uninsulated wall 4.0

INSULATION MATERIALS: R/inch
cellulose 3.7
fiber glass 3.0
polystyrene foam
expanded 4.0
extruded 5.0
polyisocyanurate 6.0 - 7.0
polyurethane 6.0 - 7.0
phenolic 8.0
window plastic (1 - 4 mil) 1.0

To calculate the R-value of a wall, for example, multiply the R-value per inch of insulation material by the thickness of the material and add R-values for the other building materials used to construct the wall.

Cost-effective Insulation R-Values*

BASEMENT: R-Value
rim joist 13
wall 5 - 11
ceiling/floor 19
crawl space 19
ducts 7 - 11
hot water pipes 3 - 11
water heater 5 - 11

Outside Walls: 11

Windows: 2 - 8

ATTICS:
attic floor 19 - 38
attic ceiling 19 - 38
sloped walls 11 - 19
kneewalls 19 - 22

*For existing (not new) homes in Michigan or a similar climate. To obtain more information on R-values, contact Urban Options or consult the Energy Efficiency and Renewable Energy Clearinghouse (EREC), PO Box 3048, Merrifield, VA 22116, Phone: 1-800-363-3732, Electronic BBS: 800-273-2955 (look in the File Libraries section for the library "Residential Energy Efficiency").

This heat-loss photo (45K), or thermogram, was taken in winter with an infrared camera. Materials with lower R-values show up brighter, indicating greater heat loss.

Insulation Materials ([top](#))

Many different types of insulation are available. In general, insulating materials should have several qualities. They should be:

- Flame/Pest/Moisture Resistant
- Low Cost
- High in R-value
- Safe and easy to use and install

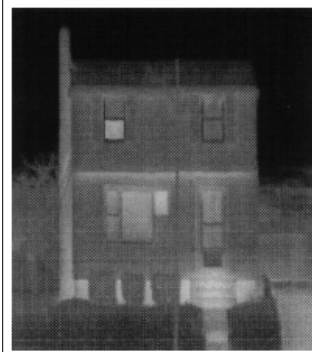

Several popular types of insulation are described below:

Cellulose insulation is usually made of ground-up newspapers and treated with a fire retardant chemical. It can be installed in attics or walls with an insulation blower.

Fiber glass insulation comes in rolls, blankets, boards, and bags. It can be purchased with a vapor barrier (faced) or without one (unfaced), and installed in unfinished attics, walls, floors, and rim joists or on ducts, pipes, and water heaters.

Foam board is typically used on brick or block walls. For interior applications, most foams must be covered with 1/2 " of fire-rated drywall or gypsum board for fire safety. For exterior applications, a protective coating should be applied to prevent deterioration in the sunlight.

Specialized products such as wraps, fabrics, blankets and foils, are available for pipes, windows, water heaters, ducts, walls and ceilings.

Safety ([top](#))

Many insulation and building materials are irritants, they should be handled carefully and appropriate safety equipment used. Always wear pants, a long-sleeve shirt, leather gloves, eye protection, and a respirator mask (approved for the material you are using) when working with insulation materials such as cellulose or fiber glass. Keep materials wrapped until you are ready to put them in place.

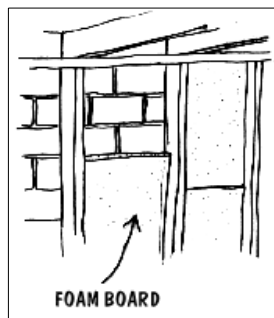

A hard hat and safety light are recommended for work in crawl spaces and attics. In attics, lay down boards or plywood sheets over the tops of joists or trusses to form a walkway (the ceiling below won't support your weight).

Electrical Fire Safety

Never insulate over recessed lights or exhaust fans. Keep insulation at least 3" away from recessed lights, chimneys, and flue pipes using metal sheeting made for this purpose. Examine all electrical wiring in the attic or floor areas before you insulate. Have wiring replaced which is broken, frayed, or connected outside of a junction box. Never handle defective wiring unless the electricity has been shut off. If you need to upgrade your electrical service, you should do so before you insulate.

Before You Insulate ([top](#))

Before you insulate, inspect for moisture problems,* structural damage, faulty wiring, leaky plumbing, and faulty gutters or downspouts. Correct any problems encountered. Be sure exterior caulking is in good condition. Seal air and water leaks.

Moisture reduces the R-value of insulation and may lead to structural, health, or safety problems.

Vapor barriers can prevent the flow of moisture into insulation. Install a vapor barrier (such as polyethylene plastic or the facing on fiberglass insulation) towards the heated living space.

Don't seal off your attic vents. These help to remove heat and moisture from your attic and crawl spaces.

Basements & Crawl Space Insulation

Many insulation projects can be found in the basement area. Basement walls, ceilings, ducts, and water heaters are the big heat losers.

Basement Walls [\(top\)](#)

The bright spots along the foundation in this infrared photo indicate the large amount of heat that is being lost through the basement walls and rim joist. In fact, a concrete block wall has about the same R-value as a single pane of glass! If you plan on heating your basement, insulate the walls (from the inside or the outside).



Exterior Wall Insulation

Extruded polystyrene foam is recommended for exterior basement walls. For Michigan frost lines, dig down 42" around the foundation to expose the uninsulated basement wall. Attach foam board with the recommended adhesive. Cover exposed

insulation with a protective coating (e.g. paint) to prevent breakdown from exposure to sunlight.

Interior Wall Insulation

Use either fiber glass or extruded polystyrene foam to insulate your inside basement wall.

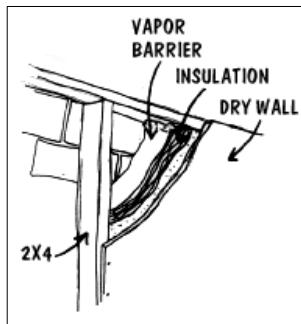

If moisture is a problem in your basement, start by correcting drainage problems and sealing the wall from potential water leaks with a vapor barrier or vapor retardant paint. Cover the whole wall with insulation. For fiber glass, install 2x4s in order to accommodate 3 1/2" batts or rolls of insulation. The vapor barrier (or paper facing, if any) should be installed next to the wall. If interior foam board is used to insulate basement walls of living areas, it must be covered with 1/2" of drywall or fire-rated gypsum wallboard.

Rim Joists

The rim joist or "band joist" area should be insulated with 6" (R 11-19) fiber glass batts.

Cut the insulation slightly larger than the width of the joist space for a tight fit. Try not to compress the insulation as this will decrease its effectiveness. The faced paper side should be installed toward the inside. The insulation should stay in place by itself, but a staple gun can be used to hold the batts in place if necessary.

Seal the joist space with pressure-fitted polystyrene and caulk around the edges. A further covering of 1/2" drywall or fire-rated gypsum wallboard will reduce fire hazards and is required by code for living areas.

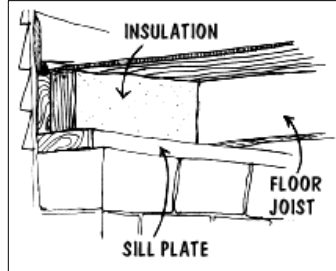

Basement Ceilings [\(top\)](#)

While it is generally best to insulate basement walls and rim joists, for some basements this is impractical. In such cases you may opt to insulate the basement ceiling instead. If you do, then you should also insulate heat ducts, pipes, etc.

Basement ceilings are typically insulated with fiber glass batts or blankets. Install a vapor barrier against the warm side. Use either faced insulation or polyethylene plastic stapled between the floor joists.

Insulation supports or "tiger teeth" are thin metal rods the size of coat hangers which can be used to hold the batts in place without compressing them.

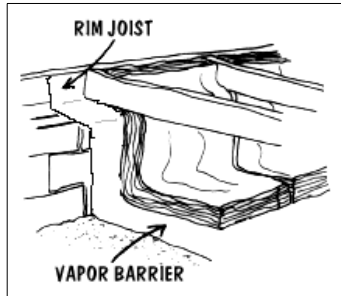
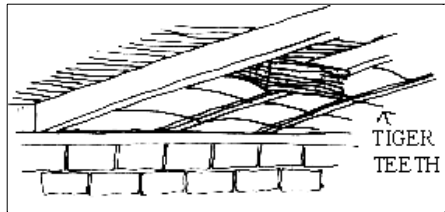

Crawl Spaces

To block water vapor from entering the crawl space, drape a layer polyethylene plastic from the rim joist down the wall and across the entire floor. Lap and tape the seams between the sheets of plastic. Then insulate either the walls and floor or the ceiling of the crawl space.

Coordinate your insulation choice for crawl spaces with the way you handle any connected basement areas. Insulating the ceiling is usually the most difficult and costly of the two choices. If you have ducts or pipes in your crawl space, you should definitely insulate the walls and floor. If it is not clear what the best choice is, consult a specialist.

For wall and floor insulation, attach fiber glass batts to the rim joist area with a staplegun. Extend the insulation two feet out from the wall onto the crawl space floor.

Vents in vented crawl spaces should not be sealed permanently or covered with insulation. The vents should be closed during heating season and open otherwise.

Floors situated over unheated spaces should be insulated. Methods are likely to be specific to the individual site. Consult your insulation supplier or contact Urban Options.

Ducts

All ductwork should be sealed. Be sure the ducts are clean and dry. Seal the seams of the ducts where air might leak. Use a high quality silicone caulk or aluminum tape.

Warm air ducts which travel through unheated areas should be insulated. These will typically be at the top of a forced-air furnace and feel warm to the touch when the furnace is operating.

Insulate ducts with vinyl-coated fiber glass, foil-coated adhesive-backed foam, or insulated duct board. Use vinyl tape to hold the insulation in place.

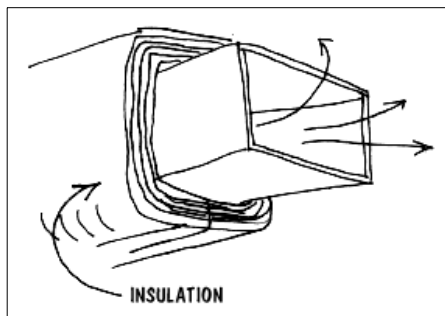
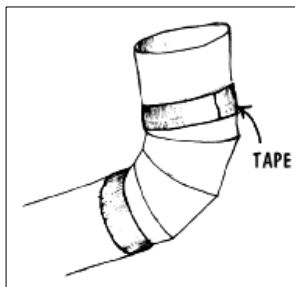

Water Heater

Next to the heating system, your water heater is one of the biggest energy users in

your home. Most older types lack built-in insulation and thus waste much of the energy used all year long. So it is important to consider whether insulating is appropriate and to take action when it is.

When to Insulate

Newer tanks that have built-in urethane foam insulation should not be further insulated. If your tank is very close to another heating apparatus, a chimney, or is placed tightly in a corner, it may not be appropriate to insulate it. Don't insulate faulty or damaged tanks either - including any tank that is rusty, leaks water, shows deterioration on the top or sides, lacks a flame door or pressure relief valve, or is situated under pipes that are likely to leak onto the tank top. If your tank makes popping or crackling noises, it probably needs replacement and should not be wrapped. If you are in doubt about the condition of your tank, consult a specialist.

How to Insulate

With gas or oil-fired water heaters, don't cover the top or the bottom of the tank. Covering the top may obstruct the venting of exhaust gases or create a fire hazard due to occasional backdrafts from the vent. Covering the bottom blocks the combustion air supply. Insulating blankets should be at least 4" above the floor.

Cut around control panels. For electric models, cut an extra 4" around the control panel to avoid overheating. For all models, keep insulation away from pressure relief valves and drain valves.

Pre-made, water heater insulating blankets are available in a variety of sizes and thicknesses. Choose one that fits your tank or make your own out of faced fiber glass insulation. Fasten the blanket securely to the tank, try not to compress it.

Pipes

Insulate the first 5 - 10' of hot water pipe starting at your water heater. This pipe will be warm to the touch. Also insulate the first 2 - 3' of the cold water intake pipe for the water heater. Hot water pipes that run through unheated, uninsulated areas should be insulated as well.

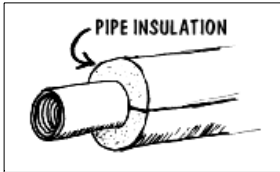

If you have a hot water or steam heating system, insulate those pipes too. Heat-resistant insulation (fiber glass or foam) is available for this purpose.

To prevent pipes from freezing that run through unheated areas - basements, crawl spaces, attics - use heat tape. For winter climates that are milder than Michigan's, insulating cold water intake pipes may be sufficient to prevent freezing.

Attics (top)

Ventilation

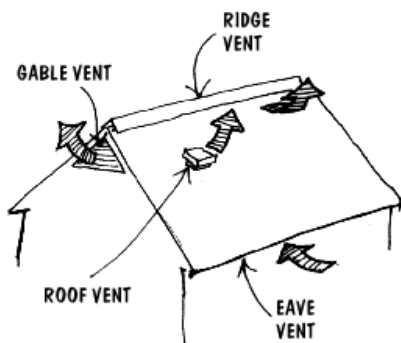

Vents are installed in the roof, gable, or eave areas to allow moisture and unneeded heat to escape from attics.

Special aluminum sheeting, also called "baffles," should be installed before you insulate to keep insulation from plugging eave vents.

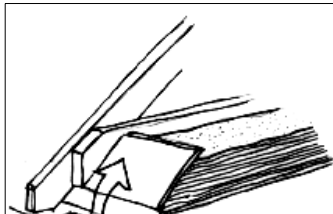

Present standards call for approximately 1 square foot of open vent area (also called net vent area) for every 150 square feet of attic floor area. If a vapor barrier is present, 1 square foot of open vent area for every 300 square feet of attic space is recommended. It is best to consult an insulation specialist if you are uncertain about ventilation types, amounts, or procedures.



Insulation

Either the ceiling or the floor of the attic should be insulated, but not both. The drawing illustrates both options. Always install a vapor barrier (toward the heated side) when you insulate.

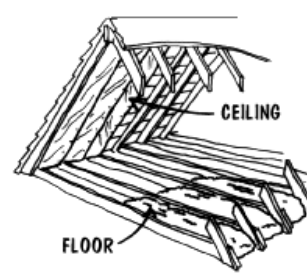

Attic Ceilings

Attic ceilings are usually insulated when you plan to finish off your attic and make it into a heated space. An R-value of 11-19 is recommended. Try to attain the highest R-value achievable for the situation you encounter.

If you insulate the attic ceiling with cellulose, it must be blown into a cavity. Create this cavity by first attaching a layer of polyethylene plastic to the ceiling rafters. Then cover the plastic by attaching fire-rated material (such as drywall) to the rafters. Block the top or bottom of the cavity, as necessary, and use an insulation blower to fill the space with cellulose.

For attic ceilings with shallow rafters, use high density insulation batts (e.g. foam board) to increase the R-value in the same space.

Faced fiber glass can be purchased which is the same width as the space between your rafters. Use the paper or foil flange on the insulation to fasten it to the attic ceiling joists.

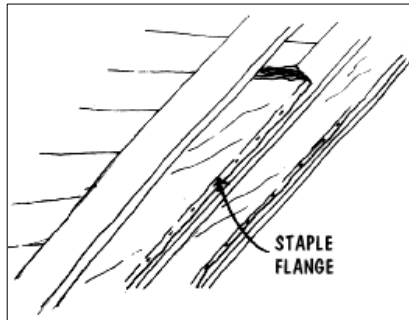

When working around wires, pipes, or other obstructions, cut the batt to fit over the obstacle. Use a straight edge, a utility knife, and a board to cut on.

To reduce air leakage and prevent moisture condensation in attic ceiling insulation, place a continuous layer of polyethylene plastic over the insulation. Lap the joints and attach with staples. Finish by applying fire-rated material over the plastic.

Attic Floors

If you're not planning on heating your attic, the floor should be insulated. This way, you'll be keeping the heat downstairs where you need it. But keep in mind that the attic still needs ventilation and a vapor barrier must be installed to prevent moisture problems and resultant structural damage. Of many options for insulation material, fiber glass (faced or unfaced) and cellulose are the most popular.

Faced fiber glass blankets can be laid snugly between the floor joists with the paper face against the floor. Unfaced fiber glass can also be used, if you place plastic down first. If some insulation is already installed or you are adding a layer to achieve a desired R-value, use unfaced (paperless) insulation. Place the second layer of insulation perpendicular to the first. (If you are going to use faced fiber glass for an additional layer, be sure to slash the vapor barrier with a utility knife so that moisture will not be trapped between the two vapor barriers.)

Cellulose is installed using a special insulation blower. Blown cellulose provides good, fast coverage of attics - even in very hard-to-reach areas. Insulation equipment can be rented from insulation companies and some tool-rental businesses, or you can hire an insulation specialist to do it for you.

Kneewalls and Slopewalls

Fiber glass batts or rolls are typically used on kneewalls. If insulation is already present, use unfaced fiber glass for an additional layer. If none is present, faced fiber glass can be installed - with the vapor barrier against the warm wall. Use a staple gun on the paper edge or foil flange to install batts snugly between the studs.

Cellulose, fiber glass, or high-density styrofoam can be used on slopewalls. If the top of the slopewall cannot be reached, you may wish to drill holes and blow in cellulose from the inside.

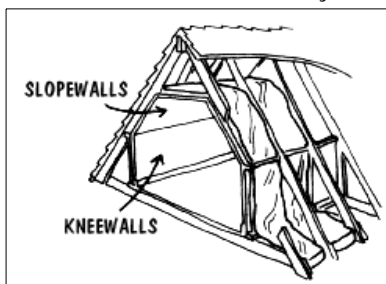

Wall Insulation ([top](#))

Insulating your uninsulated outside walls can save you a large portion of your heating bill. The first step is to determine if your walls are insulated. To do this, *turn off your electricity* and then remove a switch or outlet cover on an outside wall. Use a flashlight and look into wall cavity. If necessary, use a non-metallic object to probe for insulation.

Installation

Due to the difficulty involved with installing wall insulation, it is often best to leave this job to an insulation specialist. If you do hire one, ask two or three for written bids first and choose the one that best meets your needs (not necessarily the cheapest).

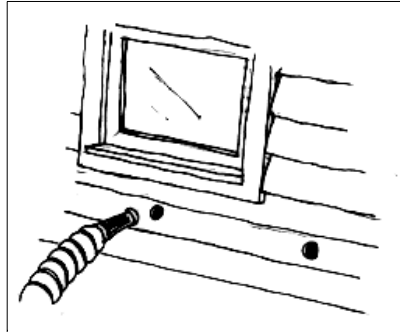

If you wish to do the work yourself, you'll have to rent an insulation blower. You'll also need a heavy-duty drill, bits, and ladders or scaffolding.

If your walls are uninsulated, bags of cellulose insulation (or fiber glass which requires a special blower) can be blown into the wall cavities. Holes are drilled at stud-width intervals (usually every 16"). The two-hole method, in which two holes are drilled into each wall cavity - one near the top of each cavity, and one in the middle - is the most effective way to fill a cavity to the proper density. Fill the middle hole first and

the top hole second. Patch the holes with wood or plastic plugs, and replace the siding.

Window Insulation: ([top](#))

Windows are like holes in your walls. They may account for 10 - 25% of fuel bills on average, and much more if you have inefficient windows and live in a very cold climate. Because of a window's inherent low R-value, improvements are relatively easy. For example, adding a storm window or sheet of window plastic to a standard window (approximately R-1) will improve its R-value by 100%, reduce heat loss, and improve comfort.

Inspect Annually ([top](#))

Inspect the house every heating season. Look for structural problems, roof leaks, faulty gutters or downspouts, drainage problems, and evidence of moisture in insulation. Check the furnace or heating system, humidifier, and air filter or cleaner. Look for loose ducts or duct insulation, and loose water tank insulation. Check chimneys and flues for obstructions, and fireplaces for cracks. Be sure smoke detectors and other safety devices are in good working condition.

Insulation Check List: ([top](#))

Location:

BASEMENT:	Present Amount	Needed
rim joist	_____	_____
inside wall	_____	_____
outside wall	_____	_____
ceiling/floor	_____	_____
crawl space	_____	_____
ducts	_____	_____
pipes	_____	_____
water heater	_____	_____
OUTSIDE WALLS:	_____	
WINDOWS:	_____	

ATTICS: _____
attic floor _____
attic ceiling _____
slopedwalls _____
kneewalls _____
attic door _____
ventilation _____

For More Information ([top](#))

In many areas of the U.S. and Canada, you can get help for you home weatherization efforts by contacting local utility companies, local governments, or state or provincial public utility commissions or public service commissions.

For more information:
call 517/337-0422
send email to information@urbanoptions.org

Urban Options wishes to thank the following individuals for their participation in developing the publication and videos: George Baker, Michelle Bosway, JoAnne Burrill, John Christian, Sin Christian, Brett Dreyfus, Mary Eimer, Irene Gibbons, Don Hannah, LeRoy Harvey, Rose Hughes, Fred Krause, Jerry Nash, James Spackman, Dennis Valade, Hector Valdez, Kathy Younglove.